INSTRUCTIONS FOR 12" CIRCULAR SAW BENCH



FOR YOUR SAFETY
READ ALL INSTRUCTIONS CAREFULLY

CONTENTS

SPECIFICATION	Page 01
SAFETY	Page 02
Specified conditions of use.....	Page 02
General safety instructions.....	Page 02
Safety devices.....	Page 03
ASSEMBLY	Page 04
OPERATION	Page 07
Setting the depth of cut.....	Page 07
Setting the saw blade tilt.....	Page 07
Sawing with the rip fence.....	Page 07
Sawing with the mitre fence.....	Page 07
MAINTENANCE	Page 08
TROUBLESHOOTING GUIDE	Page 08
TRANSPORTATION	Page 08
WIRING DIAGRAM	Page 08
AVAILABLE ACCESSORIES	Page 09
PARTS DIAGRAM&PARTS LIST	Page 10

SPECIFICATION

MOTOR POWER	SEE LABEL ON MACHINE	
MAX CUTTING HEIGHT AT 45° /90°	mm	50/90
TABLE DIMENSIONS	mm	550X800
TABLE EXTENSION(OPTIONAL)	mm	550X800
WORKING HEIGHT	mm	800
SAW BLADE DIAMETER/BORE	mm ϕ	315X3.0X30
BLADE SPEED(50/60Hz)	r/min.	2800/3400min ⁻¹
WEIGHT(NW/GW)	Kg	44/50
PACKING SIZE	mm	940X660X470

UNPACKING

NOTE: Make sure all items are accounted for before discarding any packaging material.

WARNING: To avoid injury, if any parts are missing, do not attempt to assemble the machine, do not plug in the power cord, do not turn the switch on until the missing parts are obtained and installed correctly.

HEALTH AND SAFETY GUIDANCE NOTES

Please read first!

1. Assemble tool in strict accordance with these instructions. Only if you follow the instructions exactly does the machine conform to the safety regulations and can be safely operated.
2. Read the safety instructions before initial operation.
3. Keep these instructions for reference on any issues you may be uncertain about.

Specified conditions of use

1. This machine is intended to rip and crosscut grown timber, faced boards, chip board and wood-core plywood sheets, and similar wood-derived materials.
 2. Do not cut round stock without suitable jigs or fixtures. The rotating saw blade could turn the work-piece.
 3. Any other use is considered to be not as specified and not permitted. The manufacturer is not liable for any damage caused by unspecified use.
3. Consider environmental effects:
 - Provide proper lighting.
 - Prevent adverse body positions, Ensure firm footing and keep you balance at all times. Use suitable work-piece supports when cutting long stock.
 - Do not operate tool near inflammable liquids or gases.
 4. The saw shall only be started and operated by persons familiar with circular saws, and who are at any time aware of the dangers associated with the operation of such tool.
 5. Keep bystanders, particularly children, out of the danger zone. Persons under 18 years of age shall use this tool only in the course of their vocational training, under the supervision of an instructor.
 6. Do not permit other persons to touch the tool or power cable while it is running.
 7. Do not overload tool – use it only within the performance range it was designed for (see Specifications).

General safety instructions

When using this tool observe the following safety instructions, to exclude the risk of personal injury or material damage.

Please also observe the special safety instructions in the respective chapters; where applicable, follow the legal directives or regulations for the prevention of accidents pertaining to the use of circular saws.

General hazards!

1. Keep your work area tidy – a messy work area invites accidents.
2. Be alert. Know what you are doing. Set out to work with reason. Do not operate tool while under the influence of drugs, alcohol or medication.

Danger! Risk of electric shock!

1. Do not expose tool to rain.
2. Do not operate tool in damp or wet environment.
3. Prevent body contact with earthed objects such as radiators, pipes, cooking stoves, refrigerators when operating this tool.
4. Do not use the power cable for purposes it is not intended for.

Risk of personal injury and crushing by moving parts!

1. Do not operate the tool without installed guards.
2. Always keep sufficient distance to the saw blade. Use suitable feeding aids, if necessary.
3. Keep sufficient distance to driven components when operating the electric tool.
4. Do not attempt to stop the saw blade by pushing the work-piece against its side.

HEALTH AND SAFETY GUIDANCE NOTES

5. Ensure the tool is disconnected from power supply before servicing.
6. Ensure that when switching on (e.g. after servicing) no tools or loose parts are left on or in the tool.
7. Turn power off if the tool is not used.

Cutting hazard, even with the cutting tool at standstill!

Wear gloves when changing cutting tools.

Risk of kickback (work-piece is caught by the saw blade and thrown against the operator):

1. Always work with a properly set riving knife.
2. Do not jam work-piece.
3. Cut thin or thin-walled work-piece only with fine-toothed saw blades. Always use sharp saw blades.
4. If in doubt, check work-piece for inclusion of foreign matter (e.g. nails or screws).
5. Cut only stock of dimensions that allow for safe and secure holding while cutting.
6. Never cut several work-pieces at the same time – and also no bundles containing several individual pieces. Risk of personal injury if individual pieces are caught by the saw blade uncontrolled.
7. When cutting round stock, use a suitable jig to prevent the work-piece from turning.

Drawing-in/trapping hazard!

Ensure that no parts of the body or clothing can be caught and drawn in by rotating components (no neckties, no loose fitting clothes; contain long hair with hairnet).

Never cut work-pieces containing the following materials:

- ropes
- strings
- cords
- cables
- wires

Hazard generated by insufficient personal protection gear!

- Wear hearing protection.
- Wear safety glasses.
- Wear dust mask.

- Wear suitable work clothes. When working outdoors wearing of non-slip shoes is recommended.

Safety devices

Riving knife

The riving knife prevents the work-piece from being caught by the rising teeth of the saw blade and being thrown against the operator.

Always have the riving knife installed during operation.

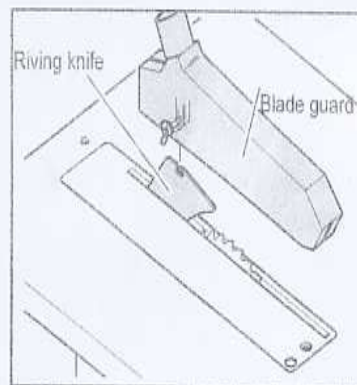

Blade guard

The blade guard protects against unintentional contact with the saw blade.

Push stick

The push stick serves as an extension of the hand and protects against accidental contact with the saw blade.

Always use the push stick if the distance between saw blade and rip fence is less than 120 mm.

Guide the push stick at an angle of 20°... 30° against the saw table's surface.

Replace the push stick if damaged.

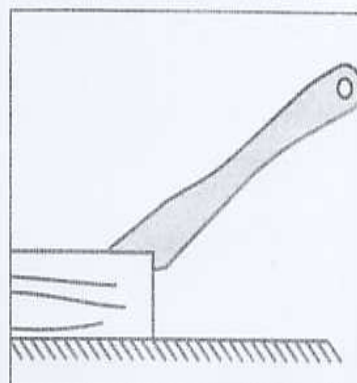

ASSEMBLY

REQUIREMENTS FOR MACHINE ASSEMBLY

- Philips screwdriver; 1X7mm wrench
- 1X22mm wrench, 1X8mm wrench; 1X17mm wrench
- 2x10mm wrenches
- 1 pair of work gloves

NOTE: The machine is supplied mostly assembled. Prior to use, the following items have to be fitted.

- Stand-Switch-Dust collect-Saw blade-Rip fence

STAND ASSEMBLY

The four folded legs have been folded before shipment.

To assemble the stand:

- unfold the four legs and tighten the wing nuts securely
- insert the short crossbeams and tighten the Knurled nut

NOTE: The carriage bolts must be positioned in the groove to fasten through wing nut.

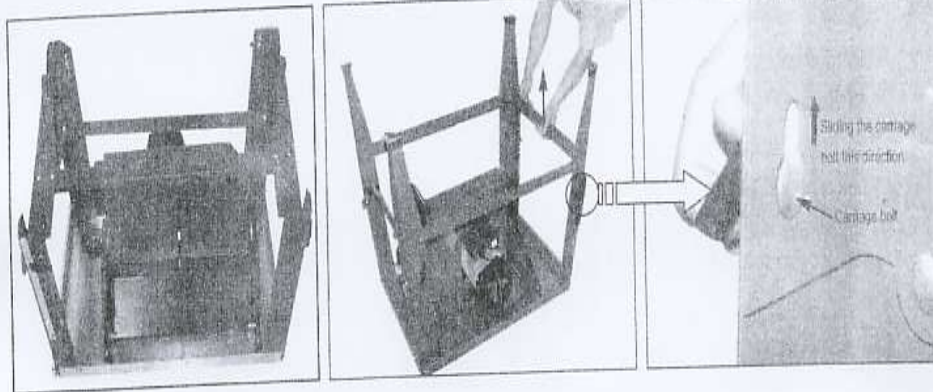

INSTALL DUST COLLECT

Attach the suction port with three tapping screws ST3.5x13 and two pan head screw M4X8 as illustrated to the outside of the chipcase.

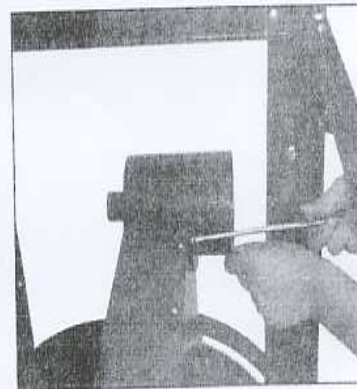

SETTING SWITCH

Fit the switch on the front panel, using the two M4 self-Locking Nut & M4X60 screws.

To start =press green switch button

To stop =press red switch button

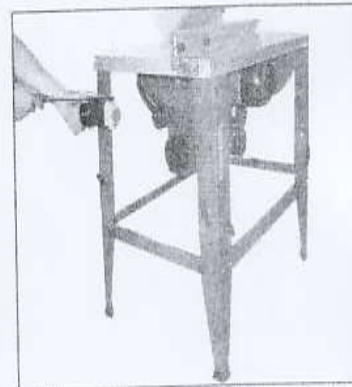

ASSEMBLY

SAW BLADE INSTALLATION

1. Raise motor fully.
2. Take the blade, the centering flange, the tightening flange, the left side nut & adjusting washer. In order, insert:
 - adjusting washer
 - centering flange
 - blade
 - tightening flange
 - left side nut

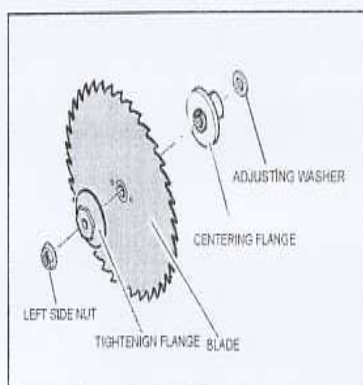

3. Insert the riving knife and tighten the nuts so that the blade guide can be made to slide according to safety norms in force.

NOTE: The distance between the blade and the riving Knife must be 3mm. Once this measurement is correct, tighten the clamp screws of the blade guard.

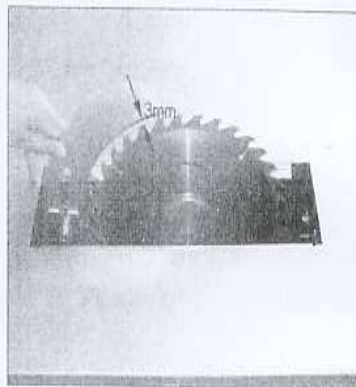

4. Position the insert table into the Table top, and pull the Insert table as show.

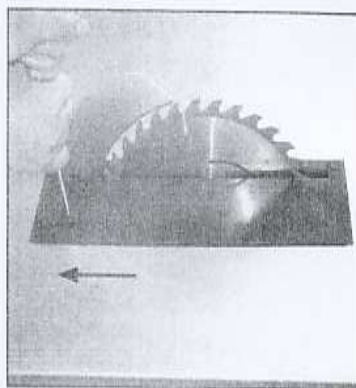

5. Install the blade guard on the riving knife, using the M5 self-locking nut & M5X50 screw.
6. Push one end of the suction hose on the blade guard's suction port

ASSEMBLY

NOTE: If necessary, crank the saw blade fully up using The handwheel to check the alignment.

- The saw blade must be aligned exactly parallel with the side edges of the table top.
- It must not touch the table insert extrusion (neither in 90 position nor in the 45 bevel position).

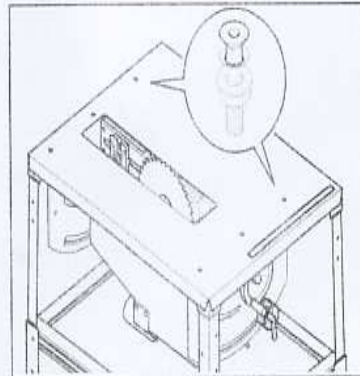

To correct the alignment:

- Loosen the six hexagonal self-locking nuts holding the fastening brackets under the saw table by approx. one turn.
- Move the fastening brackets, with the motor unit/chipcase assembly attached to it, as required, until the alignment is correct.

INSTALL RIP FENCE W/GUIDE EXTRUSION

Description	Q'ty
Fence extrusion	1
Rip fence carrier	1
Knurled nut M6	2
Carriage bolt M6X20	2
Knob M6	2
Carriage bolt M6X20	2

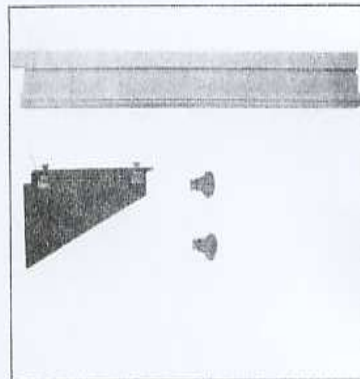

1. For use as rip fence the long fence extrusion must be installed. It is mounted on the guide extrusion at the front of the table.

2. Slide the head of the carriage bolts into the guide extrusion.



3. After loosening the two knurled nuts the fence extrusion can be removed and shifted:

Wide edge:

-for cutting thick stock

Small edge:

-for cutting thin stock

-when the saw blade is tilted.

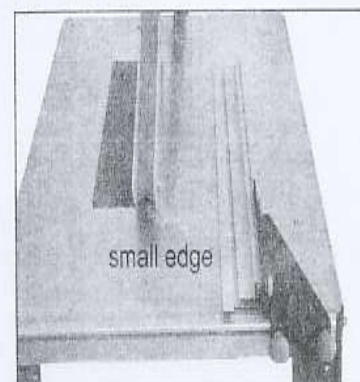

OPERATION

SETTING THE DEPTH OF CUT

The saw blade's cutting height needs to be adapted the height of the work-piece: the blade guard shall rest with its front edge on the work-piece.

Set the depth of cut by turning the handwheel on the chipcase.

Note: To compensate for possible play in the blade height setting mechanism, always raise the blade to the desired position.

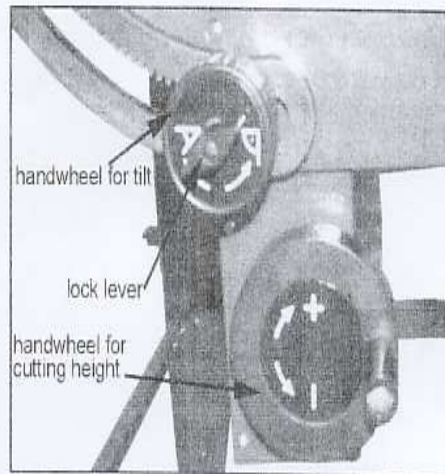

SETTING THE SAW BLADE TILT

The saw blade tilt is steplessly adjustable between 0 ° and 45 °.

1. Loosen the lock lever.
2. Using the handwheel set the desired blade tilt.
3. Tighten the lock lever to secure the saw blade in the set position.

SAWING WITH THE RIP FENCE

Note: When sawing with the rip fence the long fence extrusion must be used. And always use the push stick if the distance between saw blade and rip fence is less than 120 mm.

1. The rip fence is placed from top onto the guide extrusion at the front of the saw and locked with the lock lever.
2. Set the cutting height of the saw blade. The blade guard must rest with its front edge on the workpiece.
3. Set saw blade tilt and lock.
4. Start motor.
5. Cut workpiece in a single pass.
6. Switch machine off if no further cutting is to be done immediately afterwards.

SAWING WITH THE MITRE FENCE

1. Swing mitre fence on the table top.
2. Set to desired mitre angle and lock in that position. For mitre cuts, the fence extrusion is adjustable to 45 °
3. Set the cutting height of the saw blade.
4. Set saw blade tilt and lock.
5. Start motor.
6. Cut workpiece in a single pass.
7. Switch machine off if no further cutting is to be done immediately afterwards.

MAINTENANCE

Before switching ON

Visual check if distance saw blade –riving knife is 3mm.

Visual check of power cable and power cable plug for damage; If necessary have damaged parts replaced by a qualified electrician.

Monthly (if used daily)

Remove saw dust and chips with vacuum or brush; apply light coat of oil to guide elements:

- threaded rod and guide rods of blade rise and fall mechanism:
- swivel segments.

TROUBLESHOOTING GUIDE

Symptoms	Possible cause	Solution
Machine does not start	1.Cable is defective or broken 2.Blade is not turning due to obstruction 3.motor or connections are out of order	1.Chang feed cable 2.Remove obstructions 3.Have the motor or connections repaired by an electrician, or make replacements with new parts
Motor capacity is insufficient and is Causing overheating	The extension is too long or the section is too small	Check conditions of use
Cutting capacity is insufficient; A burning Smell upon starting the motor	1.The machine has been incorrectly assembled 2.A defect is present	1.Assemble the machine correctly 2.Replace the machine

TRANSPORTATION

1. Lower saw blade fully.
2. Adjust the bevel tilt to around 25 degree, and fold four legs.
3. Dismount add-on parts (fence, sliding carriage, table extension)
4. If possible use original carton for shipping.

WIRING DIAGRAM

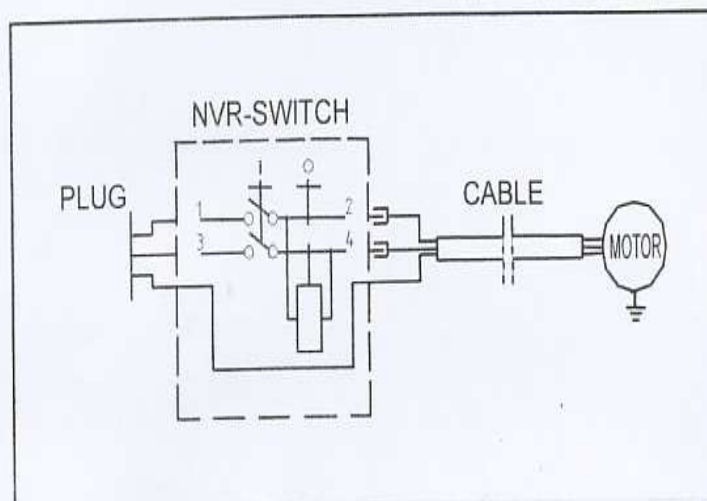

AVAILABLE ACCESSORIES

Wheel set

Description	Q'ty
Wheel A'ssy	2
Handles	2
Hexagonal bolt M6X16	4
Washer 6mm	4
Hexagonal nut self-locking M6	4
Hexagonal bolt M6X16	2
Washer 6mm	2
Hexagonal nut self-locking M6	6

Universal Wheel Set for easy moving.

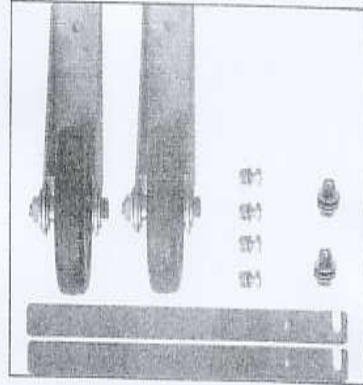

Extension table

Description	Q'ty
Extension table	1
Support (Long)	2
Support (Short)	2
Knob M6	2
Carriage bolts M6X12	2

The extension table, attaching to either rear or side.

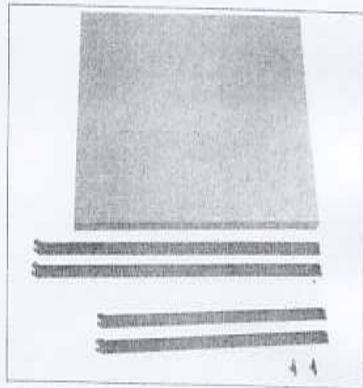

Sliding carriage

Description	Q'ty
Carriage A'ssy	1
Guide bar	1
Mitre fence	1
Guide bar support	2
Knob M6	1
Washer 6mm	1
Hexagonal bolt M6X16	1
Hexagonal nut self-locking M6	1
Washer 6mm	1
Hexagonal bolt M6X16	4
Washer 6mm	4

Sliding Carriage for convenient guiding of long stock.

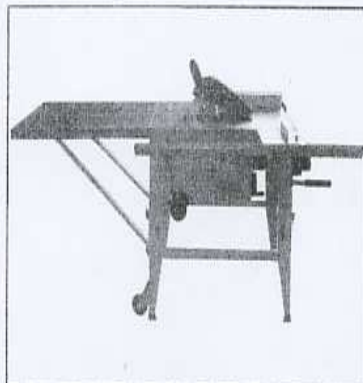
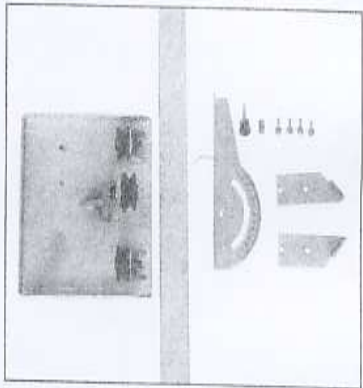
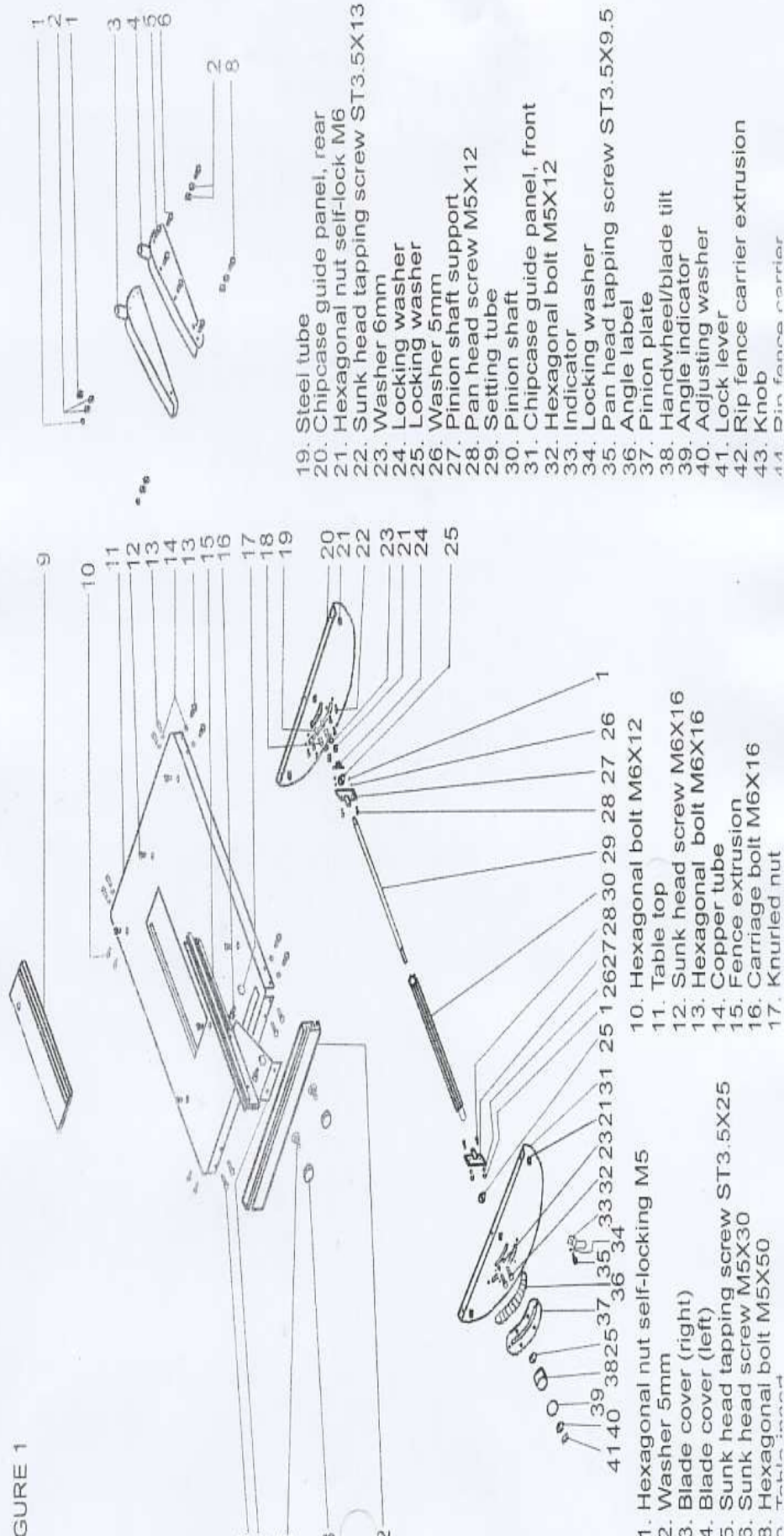

FIGURE 1



- 19. Steel tube
- 20. Chipcase guide panel, rear
- 21. Hexagonal nut self-lock M6
- 22. Sunk head tapping screw ST3.5X13
- 23. Washer 6mm
- 24. Locking washer
- 25. Locking washer
- 26. Washer 5mm
- 27. Pinion shaft support
- 28. Pan head screw M5X12
- 29. Setting tube
- 30. Pinion shaft
- 31. Chipcase guide panel, front
- 32. Hexagonal bolt M5X12
- 33. Indicator
- 34. Locking washer
- 35. Pan head tapping screw ST3.5X9.5
- 36. Angle label
- 37. Pinion plate
- 38. Handwheel/blade tilt
- 39. Angle indicator
- 40. Adjusting washer
- 41. Lock lever
- 42. Rip fence carrier extrusion
- 43. Knob
- 44. Din fence carrier

- 1. Hexagonal nut self-locking M5
- 2. Washer 5mm
- 3. Blade cover (right)
- 4. Blade cover (left)
- 5. Sunk head tapping screw ST3.5X25
- 6. Sunk head screw M5X30
- 7. Hexagonal bolt M5X50
- 8. Table top
- 9. Steel tube
- 10. Hexagonal bolt M6X12
- 11. Table top
- 12. Sunk head screw M6X16
- 13. Hexagonal bolt M6X16
- 14. Copper tube
- 15. Fence extrusion
- 16. Carriage bolt M6X16
- 17. Knurled nut
- 18. Handwheel/blade tilt
- 19. Angle indicator
- 20. Adjusting washer
- 21. Lock lever
- 22. Rip fence carrier extrusion
- 23. Knob
- 24. Din fence carrier
- 25. Pinion shaft support
- 26. Pan head screw M5X12
- 27. Setting tube
- 28. Pinion shaft
- 29. Chipcase guide panel, front
- 30. Hexagonal bolt M5X12
- 31. Indicator
- 32. Locking washer
- 33. Angle label
- 34. Pinion plate
- 35. Handwheel/blade tilt
- 36. Angle indicator
- 37. Adjusting washer
- 38. Lock lever
- 39. Rip fence carrier extrusion
- 40. Knob
- 41. Din fence carrier

FIGURE 2

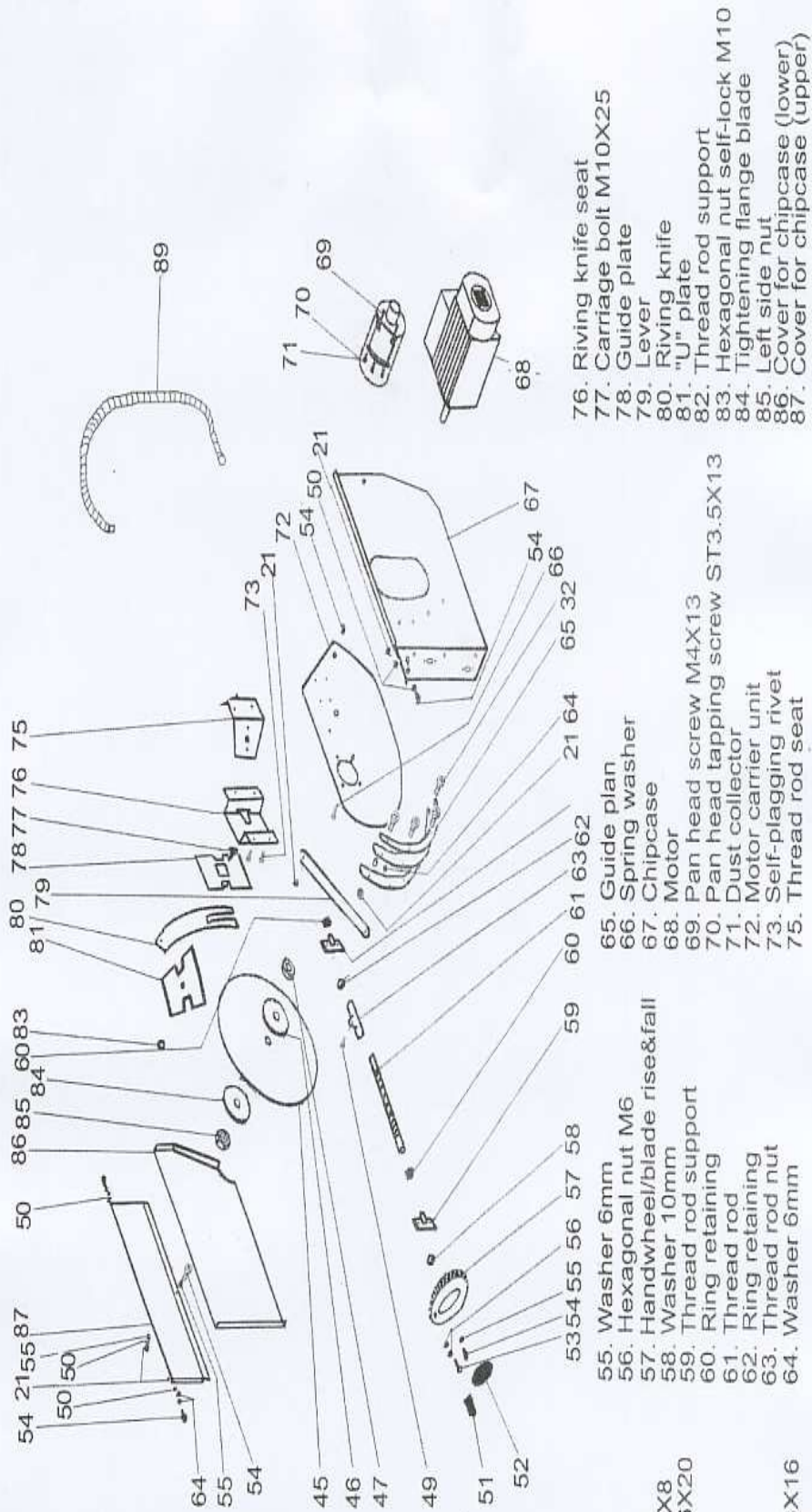
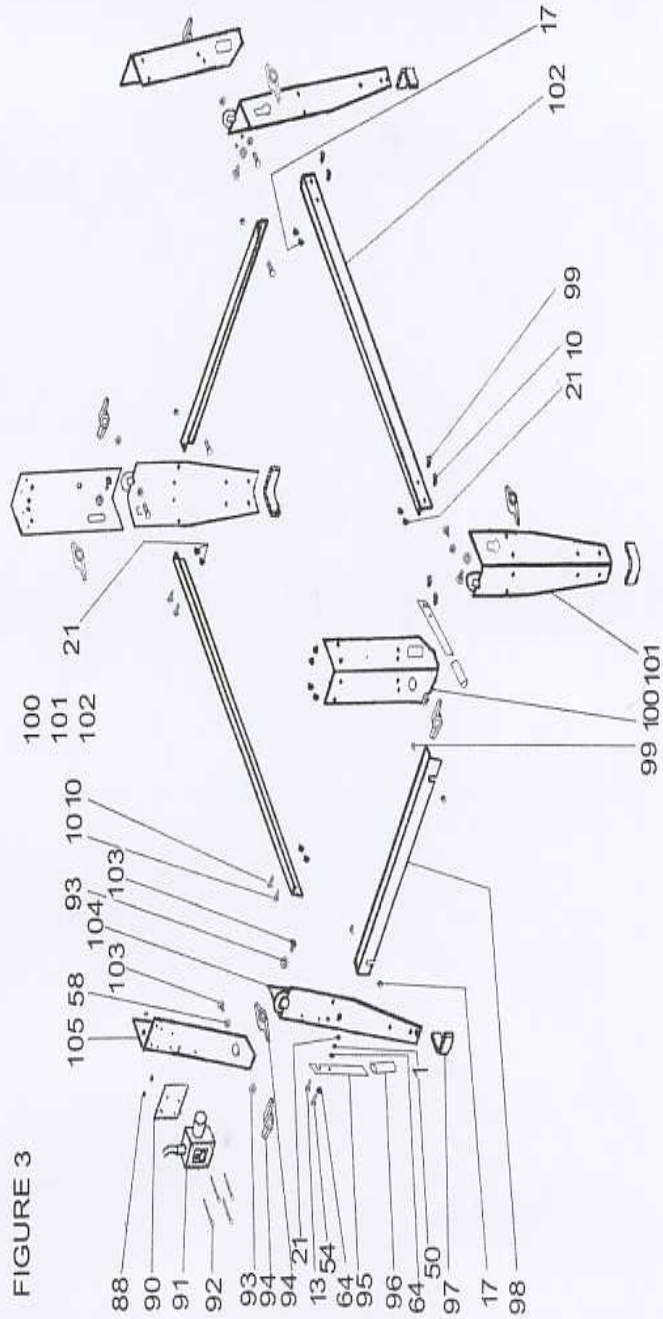

FIGURE 3



- 88. Hexagonal nut self-lock M4
- 89. Suction hose
- 90. Switch bracket
- 91. Switch
- 92. Pan head screw M4X60
- 93. Washer 8mm
- 94. Wing nut
- 95. Handle
- 96. Rubber handle
- 97. Rubber feet
- 98. Short crossbeam
- 99. Carriage bolt M4X60
- 100. Upper fold leg (right)
- 101. Lower fold leg (right)
- 102. Short crossbeam
- 103. Carriage bolt M8X16
- 104. Upper fold leg (left)
- 105. Lower fold leg (left)